

Update to Creo Parametric 2.0 from Pro/ENGINEER Wildfire 4.0

Overview

Course Code	TRN-3901-T
Course Length	2 Days

In this course, you will learn how to utilize the core functionality enhancements in Creo Parametric 2.0. First, you will become familiar with using and customizing the new ribbon interface in Creo Parametric. The new measure and sectioning interfaces will also be examined. Next, you will study the Sketcher workflow and reference enhancements, as well as Sketcher constraint, geometry, and diagnostics enhancements. Part modeling enhancements to features such as Extrude, Trajectory Rib, Point Pattern, Corner Chamfer, Sweeps, Blends, UDFs, and Datum Curves will then be examined. You will also learn about new and enhanced Assembly capabilities such as selecting multiple components, the new relationship constraints, enhancements for dragging components, explode enhancements, simplified rep enhancements, and dynamic gear enhancements. Then you will learn how to identify and resolve part and assembly failures on the fly, without entering Resolve mode. Next, you will examine the new Drawing tree and drawing sheets tabs, as well as showing annotations. Also in Drawing mode, you will learn the new Table and Balloon functionality for 2-D drawings, and review various detailing enhancements. Finally, in Sheetmetal mode you will learn to use the updated Wall, Bend, and Relief tools as well as the consolidated Flat Pattern tool and configuring Sheetmetal properties.

At the end of each module, you will complete a set of review questions to reinforce critical topics from that module. At the end of the course, you will complete a course assessment in Pro/FICIENCY intended to evaluate your understanding of the course as a whole.

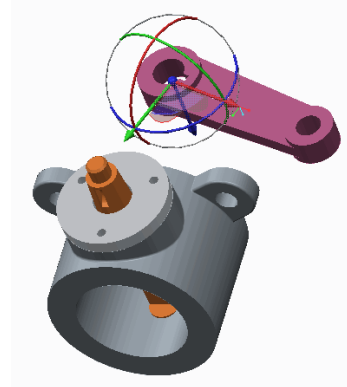

Course Objectives

- Utilize the Interface enhancements in Creo Parametric 2.0
- Utilize the Sketcher enhancements in Creo Parametric 2.0
- Utilize the Modeling enhancements in Creo Parametric 2.0
- Utilize the Assembly enhancements in Creo Parametric 2.0
- Utilize the Drawing enhancements in Creo Parametric 2.0
- Utilize the Sheetmetal enhancements in Creo Parametric 2.0

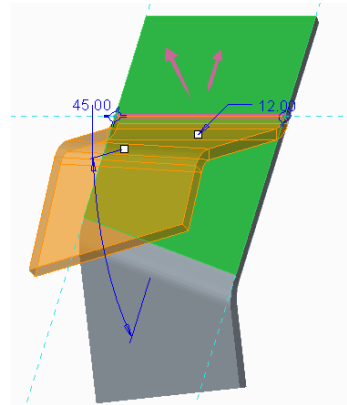

Prerequisites

- Introduction to Pro/ENGINEER Wildfire 4.0, or equivalent experience with Pro/ENGINEER Wildfire 4.0 or Creo Elements/Pro 4.0

Audience

- This course is intended for design engineers, mechanical designers, and industrial designers
 - People in related roles can also benefit from taking this course
-

Agenda

Day 1

Module	1	Interface Enhancements
Module	2	Sketcher Enhancements
Module	3	Part Modeling Enhancements
Module	4	Assembly Enhancements

Day 2

Module	5	Resolving Failures
Module	6	Drawing Enhancements
Module	7	Sheetmetal Enhancements
Module	8	Appendix

Course Content

Module 1. Interface Enhancements

- i. Understanding the Main Interface
- ii. Creo Graphics Enhancements
- iii. Understanding the Ribbon Interface
- iv. Customizing the Ribbon Interface
- v. Configuring Creo Options
- vi. Selection Enhancements
- vii. Insert Position Enhancements
- viii. Creating Layer States
- ix. Managing and Editing Appearances
- x. Locate in Model Tree Enhancement
- xi. Using the Measure Tools
- xii. Using the Measure Summary Tool
- xiii. Creating Planar Part Cross-Sections
- xiv. Creating Assembly Cross-Sections
- xv. Anti-Alias Edge Display Enhancement

Knowledge Check Questions

Module 2. Sketcher Enhancements

- i. Sketcher Interface Enhancements
- ii. Sketcher Workflow Enhancements
- iii. Utilizing Constraints
- iv. Sketching with On-the-Fly Constraints
- v. Sketcher Dimension Enhancements
- vi. Locking Sketcher Entities
- vii. Sketching Rectangles and Parallelograms
- viii. Sketching Chamfers
- ix. Sketching Ellipses
- x. Thickening Edges
- xi. Sketching Geometry Datums
- xii. Sketcher Diagnostic Tools

Knowledge Check Questions

Module 3. Part Modeling Enhancements

- i. Lightweight Hole Display
 - ii. Intersect at Surface Round Transition
 - iii. Creating Curvature Continuous Rounds
 - iv. Feature Preview Enhancements
 - v. Understanding Regeneration and Auto Regeneration
 - vi. Editing Features
 - vii. Automatically Adding and Removing Material
-

- viii. Adding Taper to Extrude Features
- ix. Creating Corner Chamfers
- x. Creating Trajectory Ribs
- xi. Variable Section and Simple Sweep Consolidation
- xii. Creating Sweeps with Open Trajectories
- xiii. Creating Sweeps with Closed Trajectories
- xiv. Analyzing Sweep Feature Attributes
- xv. Helical Sweep Enhancements
- xvi. Creating Helical Sweeps for Springs
- xvii. Analyzing Helical Sweep Profile and Pitch Variations
- xviii. Utilizing Variable Sections in Helical Sweeps
- xix. Creating Blends by Selecting Parallel Sections
- xx. Creating Blends by Selecting Non-Parallel Sections
- xxi. Creating Blends by Sketching Sections
- xxii. Analyzing Blend Section Tools
- xxiii. Analyzing Blend Options
- xxiv. Analyzing Blend Tangency
- xxv. Creating Rotational Blends by Selecting Sections
- xxvi. Creating Rotational Blends by Sketching Sections
- xxvii. Analyzing Rotational Blend Options
- xxviii. Analyzing Rotational Blend Tangency
- xxix. Creating Geometry Patterns
- xxx. Creating Point Patterns
- xxxi. Direction Patterning with Multiple Direction Types
- xxxii. Creating Axes from Coordinate Systems
- xxxiii. Creating On-Surface Coordinate Systems
- xxxiv. UDF Enhancements
- xxxv. Creating UDFs Using On-Surface Coordinate Systems
- xxxvi. Creating a Curve From Equation
- xxxvii. Creating a Curve from a Cross-Section
- xxxviii. Creating Curves Through a Point or Vertex
- xxxix. Creating a Curve Through a Point Array
 - xl. Creating Cosmetic Sketches
 - xli. Creating Cosmetic Threads
 - xlii. Using the Draft Analysis Option

Knowledge Check Questions

Module 4. Assembly Enhancements

- i. Reference Dialog Enhancements
 - ii. Assembly Unit and Mass Properties Enhancements
 - iii. Component Rename Enhancements
 - iv. Generic Instance Enhancements
-

- v. Assembly Feature Enhancements
- vi. Assembly Appearance Enhancements
- vii. Assembly Model Tree Enhancements
- viii. Selecting Multiple Components
- ix. Orienting Components
- x. Creating Coincident Constraints using Geometry
- xi. Creating Coincident Constraints using Datum Features
- xii. Creating Distance Constraints
- xiii. Creating Parallel, Normal, and Angle Constraints
- xiv. Assembling using Automatic
- xv. Utilizing the Accessory Window
- xvi. Component Operation Enhancements
- xvii. Repeating Component Placement
- xviii. Creating and Managing Explode States
- xix. Creating Explode Lines
- xx. Animating Explode States
- xxi. Retrieving Assembly Subsets
- xxii. Lightweight Graphics Representations
- xxiii. Restructuring and Reordering Assembly Components
- xxiv. Configuring Constraint Sets with Parameters
- xxv. Reviewing Assembly Changes
- xxvi. Simplified Representation Enhancements
- xxvii. Defining Simplified Reps Using the Component Chooser
- xxviii. Envelope Enhancements
- xxix. Creating and Using an All Solid Surfaces Shrinkwrap Envelope
- xxx. Creating a Default Envelope Simplified Rep
- xxxi. Mechanism Enhancements
- xxxii. Creating Generic Gear Connections
- xxxiii. Creating Dynamic Gear Connections
- xxxiv. Creating Belt Connections

Knowledge Check Questions

Module 5. Resolving Failures

- i. Understanding and Identifying Failures
 - ii. Analyzing Geometry Failures
 - iii. Analyzing Open Section Failures
 - iv. Analyzing Missing Part Reference Failures
 - v. Analyzing Missing Component Failures
 - vi. Analyzing Missing Component Reference Failures
 - vii. Analyzing Invalid Assembly Constraint Failures
 - viii. Understanding Resolve Mode Tools
 - ix. Recovering Models
-

- x. Using Creo Parametric Help

Knowledge Check Questions

Module 6. Drawing Enhancements

- i. Understanding the Drawing Ribbon User Interface
- ii. Exploring Drawing Ribbon Commands
- iii. Detailing Ribbon and Selection Enhancements
- iv. Utilizing the Drawing Tree
- v. Managing Drawing Sheets
- vi. Showing, Erasing, and Deleting Annotations
- vii. Dimension Enhancements
- viii. Detailing Enhancements
- ix. Printing Enhancements
- x. Detail Options Enhancements
- xi. Detailing Graphics Enhancements
- xii. Prefix and Suffix Enhancements
- xiii. Feature-Specific Text Enhancements
- xiv. Detailing Arrow Enhancements
- xv. Detail and Section View Enhancements
- xvi. Dimension Text Orientation Enhancements
- xvii. View Scale Enhancements
- xviii. BOM Enhancements
- xix. Inserting Tables
- xx. Editing Table Properties
- xxi. Creating Tables from File
- xxii. Creating BOM Balloons
- xxiii. Dimension and Annotation Enhancements
- xxiv. Creating Combination States and Showing Annotations
- xxv. Creating Annotation Planes and Annotation Features
- xxvi. Managing Annotation Display

Knowledge Check Questions

Module 7. Sheetmetal Enhancements

- i. Sheetmetal Properties Enhancements
 - ii. Miscellaneous Sheetmetal Enhancements
 - iii. Extending and Trimming Walls
 - iv. Creating Offset Walls
 - v. Creating Bend Features
 - vi. Adding Transition to Bends
 - vii. Creating Planar Bends
 - viii. Creating Edge Bends
 - ix. Creating Unbend Features
-

- x. Creating Bend Back Features
- xi. Joining Walls
- xii. Creating Sketched Forms
- xiii. Flattening Forms and Unstamping Edges
- xiv. Creating Split Area Features
- xv. Creating Corner Relief
- xvi. Creating Rip Features
- xvii. Converting Solid Models to Sheetmetal
- xviii. Using Conversion Features
- xix. Previewing and Creating Flat Patterns
- xx. Creating Flat States
- xxi. Punch Form Enhancements
- xxii. Utilizing Punch Model Annotations
- xxiii. Flatten Form Enhancements
- xxiv. Patterning Walls
- xxv. Mirroring Walls
- xxvi. Csys Follow Surface Option

Knowledge Check Questions

Module 8. Appendix

Knowledge Check Questions
