

Introduction to Creo Parametric 4.0

Overview

Course Code TRN-5101-T

Course Length 40 Hours

In this course, you will learn core modeling skills and quickly become proficient with Creo Parametric 4.0. Topics include sketching, part modeling, assemblies, drawings, and basic model management techniques. The course also includes a comprehensive design project that enables you to practice your new skills by creating realistic parts, assemblies, and drawings. After completing the course, you will be well prepared to work effectively on product design projects using Creo Parametric 4.0.

At the end of each module, you will complete a set of review questions to reinforce critical topics from that module. At the end of the course, you will complete a course assessment in PTC University Proficiency intended to evaluate your understanding of the course as a whole.

This course has been developed using Creo Parametric 4.0.



Course Objectives

- Learn the basic Creo Parametric modeling process
- Understand Creo Parametric concepts
- Learn how to use the Creo Parametric interface
- Select and edit geometry, features, and models
- Sketch geometry and use tools
- Create sketches for features
- Create datum planes and datum axes
- Create extrudes, revolves, and profile ribs
- Utilize internal sketches and embedded datums
- Create sweeps and blends
- Create holes, shells, and drafts
- Create rounds and chamfers
- Group, copy, and mirror items
- Create patterns
- Measure and inspect models
- Assemble with constraints
- Assemble with connections

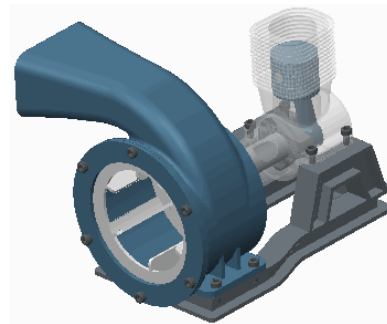

- Explode assemblies
- Lay out drawings and create views
- Create drawing annotations
- Use layers
- Investigate parent/child relationships
- Capture and manage design intent
- Resolve failures and seek help
- Comprehensive two part Design Project

Prerequisites

- None

Audience

- This course is intended for product designers, drafters, industrial/conceptual designers, and routed systems designers. People in related roles will also benefit from taking this course.
-

Agenda

Day 1

Module	1	Introduction to the Creo Parametric Basic Modeling Process
Module	2	Understanding Creo Parametric Concepts
Module	3	Using the Creo Parametric Interface
Module	4	Selecting Geometry, Features, and Models
Module	5	Editing Geometry, Features, and Models
Module	6	Creating Sketcher Geometry

Day 2

Module	7	Using Sketcher Tools
Module	8	Creating Sketches for Features
Module	9	Creating Datum Features: Planes and Axes
Module	10	Creating Extrudes, Revolves, and Ribs
Module	11	Sketcher Workflow
Module	12	Creating Sweeps and Blends

Day 3

Module	13	Creating Holes, Shells, and Draft
Module	14	Creating Rounds and Chamfers
Module	15	Project I
Module	16	Group, Copy, and Mirror Tools
Module	17	Creating Patterns
Module	18	Measuring and Inspecting Models

Day 4

Module	19	Assembling with Constraints
Module	20	Assembling with Connections
Module	21	Exploding Assemblies
Module	22	Drawing Layout and Views
Module	23	Creating Drawing Annotations
Module	24	Using Layers

Day 5

Module	25	Investigating Parent/Child Relationships
--------	----	--

Module	26	Capturing and Managing Design Intent
--------	----	--------------------------------------

Module	27	Resolving Failures and Seeking Help
--------	----	-------------------------------------

Module	28	Project II
--------	----	------------

Course Content

Module 1. Introduction to the Creo Parametric Basic Modeling Process

- i. Creo Parametric Basic Modeling Process

Module 2. Understanding Creo Parametric Concepts

- i. Understanding Solid Modeling Concepts
- ii. Understanding Feature-Based Concepts
- iii. Understanding Parametric Concepts
- iv. Understanding Associative Concepts
- v. Understanding Model-Centric Concepts
- vi. Recognizing File Extensions

Knowledge Check Questions

Module 3. Using the Creo Parametric Interface

- i. Understanding the Main Interface
- ii. Understanding the Folder Browser
- iii. Understanding the Web Browser
- iv. Setting the Working Directory and Opening and Saving Files
- v. Understanding the Ribbon Interface
- vi. Working with Multiple Windows
- vii. Managing Files in Creo Parametric
- viii. Understanding Datum Display Options
- ix. Understanding Display Style Options
- x. Analyzing Basic 3-D Orientation
- xi. Understanding the View Manager
- xii. Creating and Managing View Orientations
- xiii. Managing and Editing Appearances
- xiv. Setting Up New Part Models

Knowledge Check Questions

Module 4. Selecting Geometry, Features, and Models

- i. Understanding Creo Parametric Basic Controls
- ii. Using Drag Handles and Dimension Draggers
- iii. Understanding the Model Tree
- iv. Understanding Model Tree Filters
- v. Using the Geometry Selection Filter
- vi. Understanding Selection Filters
- vii. Selecting Items Using Direct Selection
- viii. Selecting Items Using Query Selection
- ix. Using the Search Tool

Knowledge Check Questions

Module 5. Editing Geometry, Features, and Models

- i. Renaming Objects
- ii. Utilizing Undo and Redo Operations
- iii. Understanding Regeneration and Auto Regeneration
- iv. Editing Features
- v. Editing Features Using Edit Definition
- vi. Activating and Editing Models
- vii. Deleting and Suppressing Items
- viii. Editing Feature and Component Visibility

Knowledge Check Questions

Module 6. Creating Sketcher Geometry

- i. Reviewing Sketcher Theory
- ii. Understanding Design Intent
- iii. Modifying the Sketcher Display
- iv. Utilizing Constraints
- v. Sketching with On-the-Fly Constraints
- vi. Sketching Lines
- vii. Sketching Centerlines
- viii. Sketching Rectangles and Parallelograms
- ix. Sketching Circles
- x. Sketching Arcs
- xi. Sketching Circular Fillets
- xii. Sketching Chamfers

Knowledge Check Questions

Module 7. Using Sketcher Tools

- i. Understanding Construction Geometry Theory
- ii. Sketching Points
- iii. Using Geometry Tools Within Sketcher
- iv. Manipulating Sketches Within Sketcher
- v. Dimensioning Entities Within Sketcher
- vi. Modifying Dimensions Within Sketcher
- vii. Sketcher Conflicts
- viii. Creating New Sketch Files
- ix. Placing Sections into Sketcher

Knowledge Check Questions

Module 8. Creating Sketches for Features

- i. Creating Sketches (Sketch Feature)
- ii. Specifying and Manipulating the Sketch Setup
- iii. Utilizing Sketch References
- iv. Using Entity from Edge within Sketcher

Knowledge Check Questions

Module 9. Creating Datum Features: Planes and Axes

- i. Creating Datum Features Theory
- ii. Creating Datum Axes
- iii. Creating Datum Planes

Knowledge Check Questions

Module 10. Creating Extrudes, Revolves, and Ribs

- i. Creating Solid Extrude Features
- ii. Adding Taper to Extrude Features
- iii. Common Dashboard Options: Extrude Depth
- iv. Common Dashboard Options: Feature Direction
- v. Common Dashboard Options: Thicken Sketch
- vi. Creating Solid Revolve Features
- vii. Common Dashboard Options: Revolve Angle
- viii. Creating Profile Rib Features

Knowledge Check Questions

Module 11. Sketcher Workflow

- i. Analyzing Open and Closed Sections
- ii. Creating Internal Sketches
- iii. Analyzing Sketcher Workflow
- iv. Creating Embedded Datum Features

Knowledge Check Questions

Module 12. Creating Sweeps and Blends

- i. Creating Sweeps with Open Trajectories
- ii. Creating Sweeps with Closed Trajectories
- iii. Analyzing Sweep Feature Attributes
- iv. Creating Blends by Selecting Parallel Sections
- v. Creating Blends by Sketching Sections
- vi. Analyzing Blend Options

Knowledge Check Questions

Module 13. Creating Holes, Shells, and Draft

- i. Common Dashboard Options - Hole Depth
- ii. Creating Coaxial Holes
- iii. Creating Linear Holes
- iv. Creating Radial and Diameter Holes
- v. Exploring Hole Profile Options
- vi. Creating Shell Features
- vii. Creating Draft Features
- viii. Creating Basic Split Drafts

Knowledge Check Questions

Module 14. Creating Rounds and Chamfers

- i. Creating Rounds Theory
- ii. Creating Rounds by Selecting Edges
- iii. Creating Rounds by Selecting a Surface and Edge
- iv. Creating Rounds by Selecting Two Surfaces
- v. Creating Full Rounds
- vi. Creating Round Sets
- vii. Creating Chamfers by Selecting Edges
- viii. Analyzing Basic Chamfer Dimensioning Schemes
- ix. Creating Chamfer Sets

Knowledge Check Questions

Module 15. Project I

- i. The Air Circulator
- ii. Piston Assembly Components
- iii. Crankshaft, Engine Block, Impeller, and Impeller Housing
- iv. The Frame and Bolt

Module 16. Group, Copy, and Mirror Tools

- i. Creating Local Groups
- ii. Copying and Pasting Features
- iii. Moving and Rotating Copied Features
- iv. Mirroring Selected Features
- v. Mirroring All Features
- vi. Creating Mirrored Parts

Knowledge Check Questions

Module 17. Creating Patterns

- i. Direction Patterning in the First Direction
- ii. Direction Patterning in the Second Direction
- iii. Axis Patterning in the First Direction
- iv. Axis Patterning in the Second Direction
- v. Direction Patterning with Multiple Direction Types
- vi. Creating Reference Patterns of Features
- vii. Creating Reference Patterns of Components
- viii. Deleting Patterns or Pattern Members

Knowledge Check Questions

Module 18. Measuring and Inspecting Models

- i. Viewing and Editing Model Properties
 - ii. Investigating Model Units
 - iii. Assigning Materials
 - iv. Analyzing Mass Properties
 - v. Using the Measure Tools
-

- vi. Using the Measure Summary Tool
- vii. Creating Planar Part Cross-Sections
- viii. Measuring Global Interference

Knowledge Check Questions

Module 19. Assembling with Constraints

- i. Understanding Assembly Theory
- ii. Creating New Assembly Models
- iii. Understanding Constraint Theory
- iv. Understanding Assembly Constraint Status
- v. Assembling Components Using the Default Constraint
- vi. Orienting Components
- vii. Creating Coincident Constraints Using Geometry
- viii. Creating Coincident Constraints Using Datum Features
- ix. Creating Distance Constraints
- x. Creating Parallel, Normal, and Angle Constraints
- xi. Assembling Using Automatic
- xii. Utilizing the Accessory Window

Knowledge Check Questions

Module 20. Assembling with Connections

- i. Understanding Connection Theory
- ii. Dragging Connected Components
- iii. Assembling Components using the Slider Connection
- iv. Assembling Components using the Pin Connection
- v. Assembling Components using the Cylinder Connection
- vi. Analyzing Collision Detection Settings

Knowledge Check Questions

Module 21. Exploding Assemblies

- i. Creating and Managing Explode States
- ii. Creating Explode Lines
- iii. Animating Explode States

Knowledge Check Questions

Module 22. Drawing Layout and Views

- i. Analyzing Drawing Concepts and Theory
 - ii. Analyzing Basic 2-D Orientation
 - iii. Utilizing the Drawing Tree
 - iv. Creating New Drawings and Applying Formats
 - v. Creating and Orienting General Views
 - vi. Managing Drawing Sheets
 - vii. Adding Drawing Models
 - viii. Creating Projection Views
-

- ix. Creating Cross-Section Views
- x. Creating Detailed Views
- xi. Creating Auxiliary Views
- xii. Creating Assembly and Exploded Views
- xiii. Modifying Drawing Views
- xiv. Creating New Drawings using Drawing Templates

Knowledge Check Questions

Module 23. Creating Drawing Annotations

- i. Analyzing Annotation Concepts and Types
- ii. Creating Tables from File
- iii. Creating BOM Balloons
- iv. Showing, Erasing, and Deleting Annotations
- v. Cleaning Up Dimensions
- vi. Manipulating Dimensions
- vii. Creating Driven Dimensions
- viii. Inserting Notes
- ix. Analyzing Drawing Associativity
- x. Publishing Drawings

Knowledge Check Questions

Module 24. Using Layers

- i. Understanding Layers
- ii. Creating and Managing Layers
- iii. Utilizing Layers in Part Models
- iv. Utilizing Layers in Assembly Models

Knowledge Check Questions

Module 25. Investigating Parent/Child Relationships

- i. Understanding Parent/Child Relationships
- ii. Viewing Part Parent/Child Information
- iii. Viewing Assembly Parent/Child Information
- iv. Viewing Model, Feature, and Component Information

Knowledge Check Questions

Module 26. Capturing and Managing Design Intent

- i. Handling Children of Deleted and Suppressed Items
 - ii. Reordering Features
 - iii. Inserting Features
 - iv. Redefining Features and Sketches
 - v. Capturing Design Intent in Sketches
 - vi. Capturing Design Intent in Features
 - vii. Capturing Design Intent in Parts
 - viii. Capturing Design Intent in Assemblies
-

Knowledge Check Questions

Module 27. Resolving Failures and Seeking Help

- i. Understanding and Identifying Failures
- ii. Understanding the Notification Center
- iii. Analyzing Geometry Failures
- iv. Analyzing Open Section Failures
- v. Analyzing Missing Part Reference Failures
- vi. Analyzing Missing Component Failures
- vii. Analyzing Missing Component Reference Failures
- viii. Analyzing Invalid Assembly Constraint Failures
- ix. Recovering Models
- x. Using Creo Parametric Help

Knowledge Check Questions

Module 28. Project II

- i. The Air Circulator
 - ii. Piston Assembly
 - iii. Engine Block and Drawing
 - iv. Blower Assembly
 - v. Engine Blower Assembly
 - vi. Completing the Design
-